

CAA-500 MarkII

C★MET ANTENNA

Standing wave Analyzer
1.8 - 500MHz

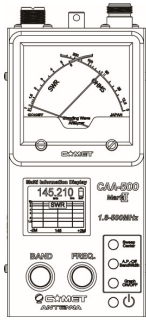

Instruction Manual

Thank you for your purchase of this instrument. It was built under tight quality control standards and procedures; however, there is always the possibility of damage during shipping. Should this occur, please notify the dealer from whom you purchased it immediately so they can initiate the damage claim process with the shipping company. Please read this manual completely before beginning operation, so as to understand its features and capabilities fully.

◆Features

- The CA-500 MarkII has a wide-range signal oscillator covering 1.8-500 MHz, enabling measurement of important antenna system parameters including impedance and Standing Wave Ratio (SWR).
- The dual analog meter, combined with the LCD display, allows simultaneous display of SWR and impedance.
- The color TFT display permits easy viewing of frequency and band information, even in the dark.
- The Band Sweep function allows you to measure SWR across the selected ham band and view it on the display graph. You can also define a center frequency and frequency span for display of the SWR characteristics.
- The programmable Auto Power Off function preserves battery capacity in case you forget to turn the meter off.
- You can use 6 AA alkaline or Nickel-Metal Hydride (NiMH) batteries to power the meter. Up to ten hours of operation are possible using alkaline AA cells.
- External 8-16V DC power may be used to power the meter; this also allows trickle charging of a NiMH battery.
- A hand strap is provided, for ease of use and to minimize the chance of dropping the CA-500 MarkII.



Important Cautions

- ◆ This is a delicate measuring instrument; please take care not to drop it or subject it to physical shock.
- ◆ The impedance bridge of this instrument is immediately inside the antenna connection point. Because there is no protection for the bridge, ***be absolutely certain not to apply power from an external transmitter.***
- ◆ Strong local RF fields (in a multi-station environment, for example) may cause unstable SWR readings.
- ◆ In order to protect the detector elements in this unit, please be sure to discharge any static electricity buildup on the antenna by shorting the center pin of the connector on the coax line to ground before testing.
- ◆ This unit is normally powered by six AA alkaline or NiMH cells. You may also apply external DC in the range of 8-16V. The external DC supply should be well regulated, and capable of at least 250 mA of current. Be absolutely certain not to exceed the 16V maximum voltage limit. Do not apply AC voltage of any kind.
- ◆ If using AA alkaline cells to power this unit, when the battery voltage becomes low the LCD display will falter and measurements will become unstable. Replace all six batteries with fresh ones (do not mix old and new). If you do not use the meter for a long time, remove the batteries to prevent damage from leakage.
- When not using NiMH batteries, please turn OFF the Charge switch on the battery case. Failure to do so might result in battery rupture or leakage if you apply charging voltage to alkaline cells.
- This product is intended for amateur radio measurement applications only (not certifiable professional testing). Calibration of this unit for amateur applications is available (fee will apply).

◆ Panel/Case Parts and Descriptions

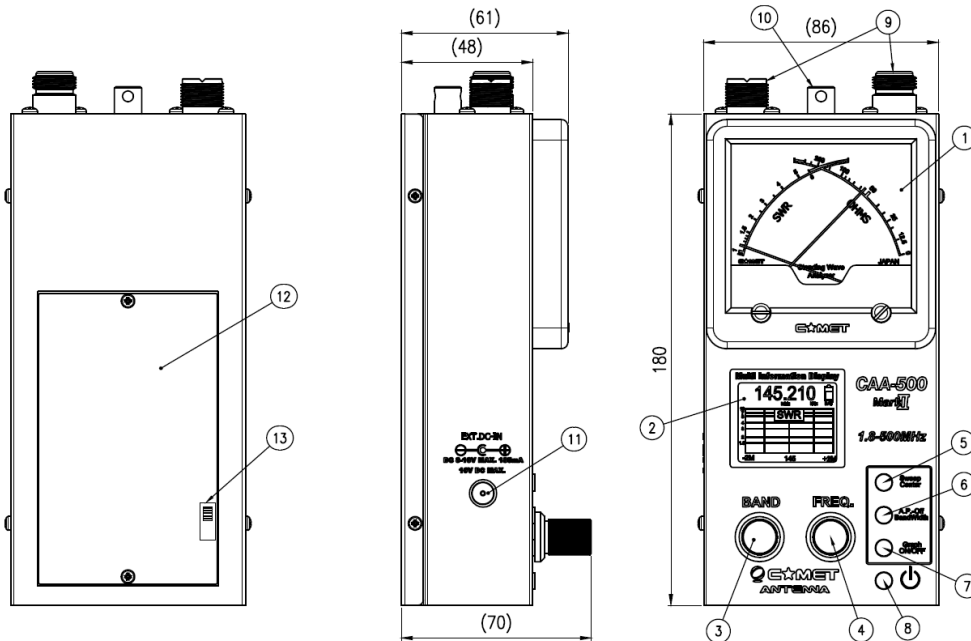

① **Display Meter** This Cross Meter displays both SWR and Impedance simultaneously.

② **Multi-function Display** The color LCD (Liquid Crystal Display) shows frequency, amateur band, and SWR data (impedance (Z)/resistance (R)/reactance (X)) and also can provide a swept-frequency SWR graph.

③ **BAND Knob** This knob is used to select the frequency band within the range 1.8 to 500 MHz. Clockwise rotation of this knob selects a higher frequency band. It is also used for setting of the APO (Automatic Power Off) function.

④ **FREQ. Knob** This knob is used to set the frequency within the selected amateur band. Clockwise rotation increases the frequency, while counter-clockwise rotation lowers the frequency.

⑤ **SWEEP/CENTER Button** In the “Normal” mode, pressing this button starts an SWR sweep of the band. •When in the SWR Graph mode, pressing this button sets the current display frequency to be the center frequency of the graph. In this mode, rotate the (3) BAND knob to adjust the Sweep width; press the (6) A.P.OFF/WIDTH button to confirm. Now rotate the (4) FREQ knob to display the SWR plot.

⑥ **A.P.-OFF/BANDWIDTH Button** In the “Normal” mode, press and hold in this button for three seconds to allow setting of the Auto Power Off feature’s time interval. •In the “Manual” plot mode, pressing this button allows you to set the bandwidth of the SWR Sweep. •While in the “Manual” plot mode, pressing this button allows you to change the color of the SWR Graph.

⑦ **GRAPH ON/OFF Button** Press this button to switch between the “Normal” mode and the SWR Graph modes.

⑧ **POWER Button** This is the main Power On/Off button for this device. Press once to turn the unit on, and again to turn it off.

⑨ **RF Connectors** These are the coaxial jacks used for connection to the coaxial cable. The left connector is an “M (“UHF”) type (used for 1.8-300 MHz), while the right jack is Type N, used for 300-500 MHz. Switching is automatic, based on the Band setting.

⑩ **Hand Strap Mounting Bracket** You may connect a commercially-available hand strap here. As the diameter of the mounting hole is greater than 1 mm, a sturdy strap (highly recommended) may be attached.

⑪ **External DC Power Terminal** External DC (8-16V) may be connected here. The center pin is positive (+).

⑫ **Battery Case** This is the housing for six AA cells. Please install them according to the inscription inside the case.

⑬ **Charge Switch** (Inside Battery Case) This is the switch for enabling/disabling trickle charging of NiMH cells, if used.

When using Alkaline or similar batteries, be sure to set this switch to the OFF position. In the event of battery leakage, serious damage to this unit may occur if the switch is set to ON during use.

(⊗) Trickle charging is useful to help maintain a full charge on your battery by compensating for the slight self-discharge that can occur even without a load being placed on the batteries

Before You Start

This instrument has been calibrated with the unit lying horizontally, with the meter facing up. The discussion below is an operating example; the parameters you set may affect the actual results.

Always be sure that you connect your coaxial connector to the proper connector. If you are connected to the opposite connector, measurements will be impossible and if the wrong connector is used, damage to the jack may occur.

▲OPERATION

It is helpful to review operation before commencing operation. Steps (1) and (3) may be omitted once you have verified that the unit is operating properly.

- ① Connect a 50-Ohm dummy load (not supplied) to the “M” (“UHF”) jack.
- ② Press the POWER switch to turn the unit on in the Normal mode.

Normal Mode Display Screen

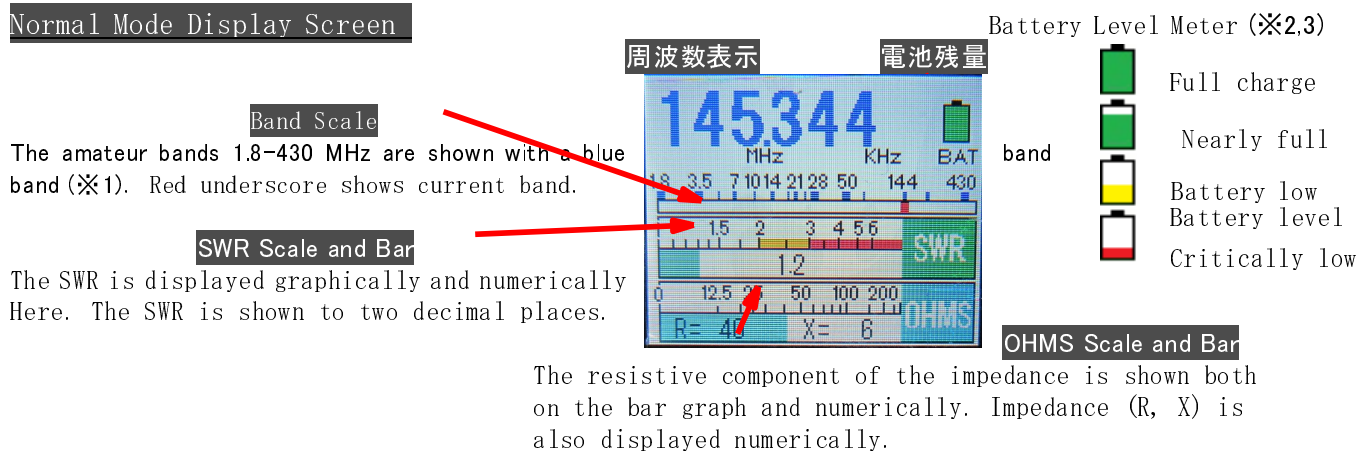

※1 Note that not all the annotated amateur radio bands are available in all countries.

※2. If using Nickel-Metal Hydride batteries, the battery status meter will never show “Full.” You should recharge the batteries once the Yellow indication appears. If using alkaline cells, replace when the Yellow indicator appears.

- ③ When connected to a 50-Ohm dummy load, the SWR indication should be 1.1 or less. If so, the meter is performing correctly.
- ④ Perform measurements according to the discussion below.

▼SWR Measurement

- Connect the coaxial cable to the meter; use the shortest possible cable between the antenna and meter, as any cable between the antenna and meter can transform the measured impedance, and feedline loss can also cause the displayed SWR to be better than it actually is. See FAQ later.
- Set the BAND and FREQ knobs to the band and frequency to be tested on the antenna.
- You may now read the SWR and resistive value of impedance (OHMS) on the display. If there is a subtle difference between the mechanical and the LCD, the precision of the mechanical meter has priority.

About the Reactance Display

The display of impedance on the LCD includes both resistive (R) and reactance (X) indications. Note that the X display is absolute value, so the polarity (+ or -) cannot be viewed.

▼Measurement of Antenna Resonant Frequency

■ Connect the antenna to the appropriate antenna connector on the meter, using the shortest possible cable. If you use a long cable, the measurement will also include the effects of feedline loss, and impedance differences between the antenna system and coaxial cable will not show the actual antenna impedance.

■ While watching the frequency display, rotate the FREQ knob while observing SWR. If you rotate the FREQ knob to the point where the frequency no longer changes, change the Band to set a new range.

■ The frequency at which the minimum SWR is observed is the resonant frequency for the system.

Incidentally. . .

Because of stray inductance and capacitance, it is possible for the meter to show a “quasi” resonant frequency. If the measured “resonant” frequency is different from what you expected, inspect your system for these possible issues, in addition to those mentioned previously.

◆Using the Graph Mode to Display SWR vs. Frequency

There are two types of Graph mode on this meter. You may use a predetermined center frequency and bandwidth to perform an SWR sweep, and alternately you may set an arbitrary center frequency and bandwidth to perform a manual SWR sweep.

Auto Sweep Mode (“SWR” caption around center of Graph shown in Red)

1. While in the Normal display mode, press the SWEEP/CENTER button to initiate an automatic sweep. The center frequency and sweep bandwidth will be based on the Band that is currently selected.
2. While the Sweep is in progress, the “SWR” caption will blink. A band Sweep typically takes about 25 seconds to complete.
3. Once the Sweep is completed, you may repeat the Sweep as many times as desired by just pressing the SWEEP/CENTER button again.
4. To return to the Normal Mode, press the GRAPH ON/OFF button. Note that the FREQ and BAND knobs are disabled in the Sweep Mode.

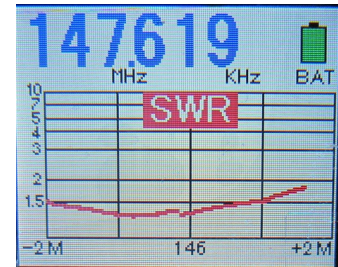

Auto Sweep Mode

Manual Plot Mode (“SWR” caption around center of Graph shown in Green)

1. While in the Normal display mode, press the GRAPH ON/OFF button to enter the Manual Plot mode.
2. The SWR Graph will now be displayed; use the BAND and FREQ knobs to set the desired center frequency for the manual SWR Sweep.
3. Press the SWEEP/CENTER button.
The center frequency (rounded to three digits) will appear in the center of the Graph, and the Sweep Limits (left and right at bottom) will blink.
4. Use the BAND and/or FREQ knobs to set the Sweep bandwidth, then press the A.P.OFF button to confirm the setting.

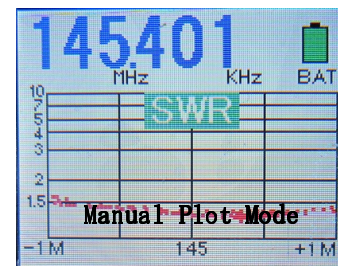

- Because the BAND knob causes huge frequency shift, generally you will use the FREQ knob to set Sweep Limits.
5. After the setup is finalized, rotate the FREQ knob to perform the Manual Sweep. Gradual rotation of the FREQ knob allows precision measuring to be performed (minimum resolution 1 kHz).
 6. If you press the AP-OFF button during a Manual Sweep, the color of the plot will change (Red -> Blue -> Green -> Purple -> Orange -> Red . . .).
 7. If you want to change the bandwidth in this mode, press the SWEEP/CENTER button again.
 8. To return to the Normal mode, press the GRAPH On/OFF button.



Note: You can not preserve the Graph data if you change Graph Modes

●Setting the Auto Power Off Time

■ This procedure sets the Auto Power Off timer, to preserve battery life after meter inactivity. In the Normal mode, press and hold in the A. P. OFF button for more than three seconds; the currently-set Auto Power Off time will be shown on the display. Rotate the BAND knob to change the timer in one-minute increments (0 – 9 minutes). When done, Press the A. P. OFF button momentarily.

- If the timer is set to 0 minutes, the Auto Power Off function will be disabled.
- When power is turned off, this setting will be saved.

Rotate the BAND knob to change the APO time.

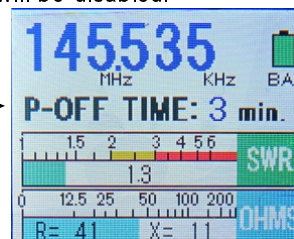
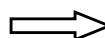

• Note that the meter will consider frequency change of less than 3% to be “inactivity” when counting down the Auto Power Off timer.

Quick-Reference Operation Chart

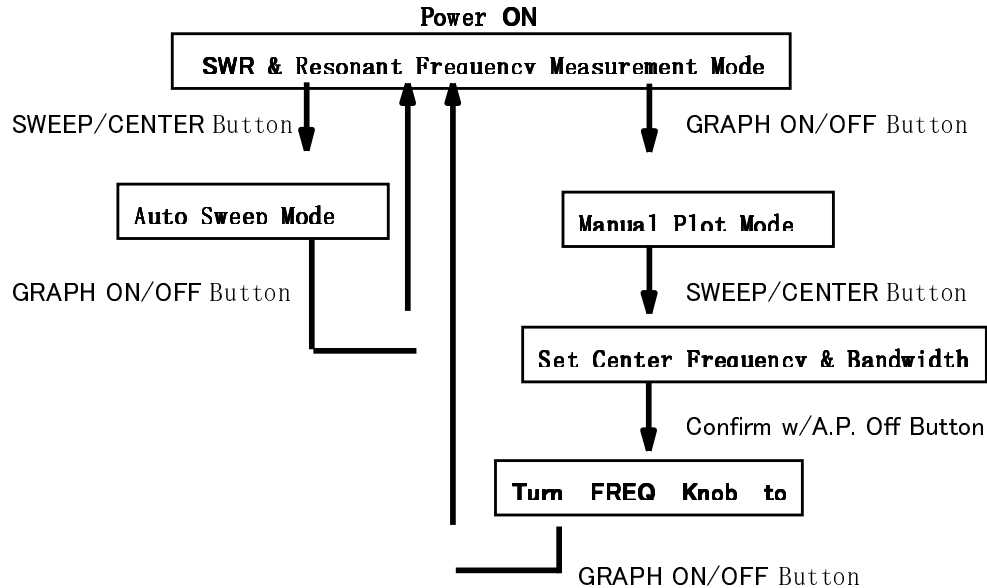

● Regarding the Charging and Use of Nickel-Metal Hydride (NiMH) Batteries

- This meter can be used either with alkaline or NiMH rechargeable batteries.
- If using NiMH batteries, they may be trickle charged inside the case.
- To trickle charge NiMH batteries, you must set the small slide switch inside the case (near the battery holder) to the CHARGE ON position.
- When the battery level indicator changes from yellow to red, apply 12-14V DC to the DC IN jack to trickle charge the NiMH batteries. A full charge takes about 14-15 hours.
- Charging of NiMH cells can be done with as little as 8V DC, but it may take several dozen hours to achieve a full charge. If the DC voltage is above 14V, the batteries may charge, but their lifetime will be shortened.
- Trickle charging will occur, regardless of the setting of the Power On/Off Switch, if 12-14V DC is present at the DC IN jack.
- The trickle charge current is very low, but we recommend that you turn off and disconnect the DC power source used for charging if you will be away from the unit for a long time.

Be certain to turn the charging slide switch to OFF when using alkaline cells!

If you neglect to turn this switch off, and attempt to charge alkaline cells, battery leakage may occur, which can cause serious damage to this unit (not covered by our Limited Warranty). Also, do not use a combination of alkaline and NiMH batteries, as damage can occur in case of an unexpected accident.

● About Error Messages

If an error occurs during Sweep operation, an error message will appear at the top right. In this case, ER1 indicates that the frequency of interest could not be set.

Frequently, very strong local RF fields can cause erratic meter operation and/or incorrect SWR readings. Try to eliminate the strong RF fields and try again.

If ER1 appears even with no antenna connected, there may be an internal malfunction in the meter. Contact your dealer for repair assistance.

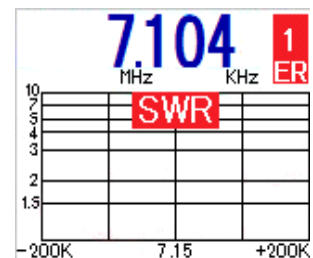

If ER2 appears immediately after powering up the unit, it means that the internal flash data is corrupted.

Recovery Procedures

1. Press and hold in the GRAPH ON/OFF key; while holding it in, press the POWER key to turn on the CA-500 MarkII.
 - Release the GRAPH ON/OFF key when prompted.
 - The version number for the unit's firmware will; now appear on the LCD.

2. Now press the GRAPH ON/OFF key.
 - [BAND A] will be displayed.

3. Press the GRAPH ON/OFF key again.
 - [AUTO: 1] will be displayed.
 - Set the FREQ knob to the center of its range.
 - Do not move the FREQ knob hereafter during this procedure.

4. Press the CENTER key. An automatic adjustment process will begin; you will notice a number incrementing upward.

5. After about two minutes, [COMP: 35] will be displayed. The procedure is now complete.

6. Now turn the CA-500 MarkII off.

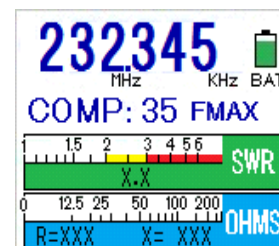
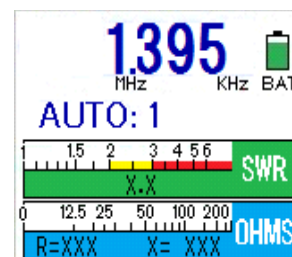
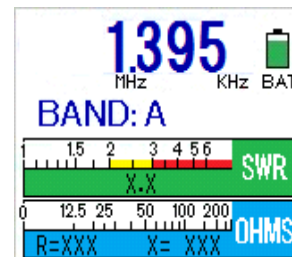
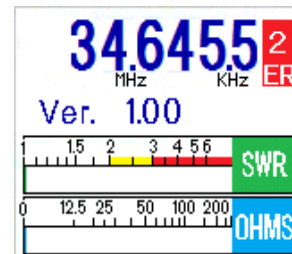
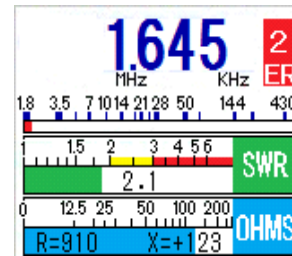

FAQ –Frequently Asked Questions–

(Before Contacting Us)

Q. When the antenna connected, the resonant frequency appears shifted or there is no SWR dip.

A. On an antenna not requiring radials, the case of this unit is the “ground” and it is possible, due to common mode current flow or other reasons, that the meter may be situated in a position that causes radically unusual readings to occur. Try to relocate the meter as close to the antenna as possible to see if this eliminates the problem.

Q. Even with a known 50-Ohm impedance, the SWR does not indicate a low value.

A. The impedance that you are viewing is an absolute value that also contains a reactance. It is possible to have the meter show 50 Ohms of impedance without a 1:1 SWR.

Try to get the reactance as close to zero as possible; in this instance, with a total impedance of 50 Ohms and nearly zero reactance, the SWR will be 1:1 (ideal situation).

In this MkII version, a reactance display has been added. Because it shows the absolute value of reactance (no “+” or “-”), you cannot initially tell if the reactance is capacitive or inductive. Generally, if the impedance is capacitive (-), then making the antenna shorter (in the case of a dipole or Yagi driven element) will cause the reactance to increase. If the impedance is inductive (+), making the antenna longer will cause the reactance to increase.

Q. At what point do I want to use a cable for attachment to the antenna?

A. To get the most accurate reading of the impedance, the meter should be either immediately at the feedpoint for the antenna (often impossible) or connected via an integer multiple of a half wavelength of cable at the frequency being measured. However, feedline loss may affect the results even in this case, so you will not see the antenna performance alone, but rather the antenna + cable system performance.

When computing a half-wavelength cable, the velocity factor of the cable must be included. For example, the velocity factor of RG-213 type coax is typically 67%. So for 14 MHz this is 492×12 (for inches) = 5904 divided by 14 (MHz) $\times 0.67 = 421.71$ inches (including velocity factor).

Depending on the cable diameter and attendant losses, the use of cable lengths in excess of 30m (about 100') may yield inaccurate readings, due to the very low power of this unit.

Q. Is it possible to connect to the “M” (“UHF”) and “N” (Type N) jacks simultaneously?

A. Because the jacks are automatically switched, according to the frequency in use, there is no way that both jacks may be used simultaneously (the opposite connector cannot be used in case of an incompatibility).



Notes on Handling

● This unit is fragile: do not drop or subject it to a strong shock.

Physical damage and/or malfunction may occur if unit is dropped.

● Do not use in very dusty or damp places, or outside in the rain.

This unit is not waterproof nor dustproof, so damage can occur.

● Please do not disassemble or modify this unit.

To do so may present danger due to electrical shock; product failure or failure to meet specifications may occur if modified.

● Please use only at a temperature between 0° and +40° C (+32° to +104° F).

The Liquid Crystal Display (LCD) may malfunction at low temperatures.

◆ Product Specifications

Frequency Range	1.8 – 500 MHz in 35 range segments
RF Output Level	0 dBm (1 mW)
Measured SWR Range	Analog Meter: 1.0 – 6.0; LCD: 1.0 – 9.9
Impedance Range	12.5 – 300 Ohms (Analog and LCD)
Resistance Range	10 – 500 Ohms
Reactance Range	0 – 500 Ohms (Absolute Value)
RF Connectors	“M” (“UHF/SO-239”) for HF/VHF, “N” for UHF
Operating Temp.	0° – 40° C (32° – 104° F)
Power Sources	6 x Alkaline or NiMH Rechargeable Cells External Power: +8 to +16V DC
Current Consumption	185 mA or less
Charging Time	15 hours at 12 – 14V DC (trickle charge)
Dimensions	89 (W) x 196 (H) x 70 (H) mm (incl. knobs/jacks)
Weight	800g (unit only), 940g (w/batteries)
Supplied Accessory	External DC Cable (Center pin +)

For After-sale Service

- For questions about this product, contact your dealer or our Technical Support staff
- ◆ For repairs or in case of shipping damage, consult the dealer from whom this unit was purchased.
- For further information about our Limited Warranty, please consult the warranty card supplied with this unit.

Specifications for this product are subject to change without notice or obligation, in the interest of ongoing product improvement.

COMET CO., LTD.

Tsuji 4-18-2, Minami-ku, Saitama-City, Saitama 336-0026 JAPAN

TEL: +81 048-839-3131 , FAX: +81 048-839-3136

URL <http://www.comet-ant.co.jp>

1st edition. May 2015
Copyright (C) 2015 COMET CO, LTD. All Rights Reserved.